

Options for the Cube

Geared panning (gp)

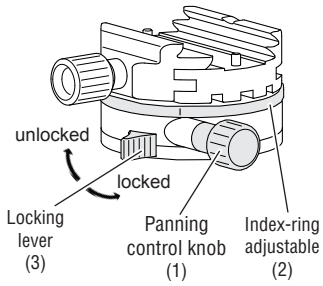

When first using your gp panning control knob (1), the gearing may feel stiff, requiring a bit of effort to turn the geared panning knob.

This is normal for a new gp head. After a short period of break-in time the gp head will smooth out and turn easier.

Please note — The index-ring (2) under the quick release is user adjustable. The index mark on the index-ring can be moved to a starting point for a series of panoramic captures or can be left at the zero position. To stop the panorama rotation, the locking lever (3) must be moved to the right.

Incremental panning ClicPan® (cp)

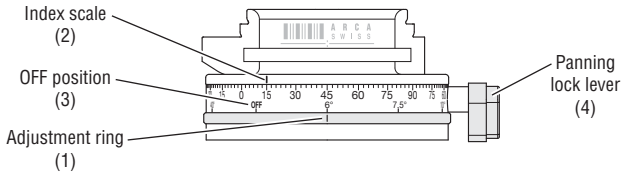

(1) Select a panoramic overlap interval by rotating the white index mark on the clicPan® (brass) adjustment ring. Rotate the ring until the index mark is aligned with your preferred interval detent setting.

Ten positions are provided on the lower scale - 40° (9 stops), 30° (12 stops), 24° (15 stops), 20° (18 stops), 15° (24 stops), 12° (30 stops), 10° (36 stops), 7.5° (48 stops), 6° (60 stops) with an "OFF" position for 360° free panning movement.

The clicPan® adjustment ring will turn in either direction. When rotated, the adjustment ring will stop and "click" into the next detent setting.

Once a setting has been chosen, the mounted camera will pan in equal increments through a 360° radius, with an audible "click" at each position.

(2) The degree of rotation can be visually checked using the upper index scale.

(3) Move the clicPan® ring to the "OFF" position when 360° free panning is required.

(4) To stop all panning rotation, tighten the upper panning lock lever.

The upper pan must be unlocked when making incremental panoramic captures using one of the detent settings.

ARCA-SWISS Cube



We recommend

ARCA-SWISS QuickLink



Finally a professional solution that eliminates the tedious fixing of the tripod head.

ARCA-SWISS presents the new tripod mounting QuickLink. The combination of a mounting plate for the tripod and an insert plate which is attached to the tripod head makes attaching and detaching the tripod head child's play. The installed plates can thus be left permanently on the tripod or on the tripod head.

By means of a solid bayonet, the tripod head with its insert plate is placed into the mounting plate and securely fixed by a knurled rotating ring.

Leather bag



On our oiled leathers, because of temperature and moisture variations white spots can appear coming from the excess of oil resulting from the tanning process to create water resistant leather. This is the natural breathing of oiled leather. To remove these white spots you brush either softly or use „dry cleaning solvent“ on a towel. Never add oil or wax to clean these white residues. When leather is wet, never dry it near a heat source. Brush them regularly and for dirt, clean them with water or water and soap, then rinse.

ARCA-SWISS X-table System

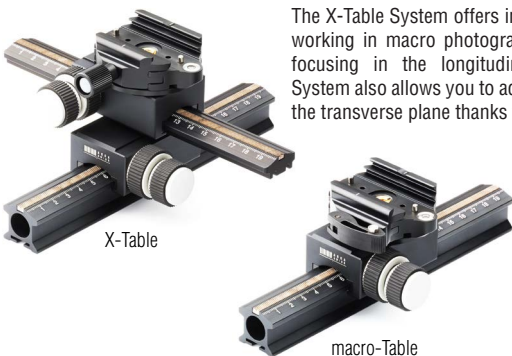

The X-Table System offers incredible precision when working in macro photography! In addition to fine focusing in the longitudinal plane, the X-Table System also allows you to adjust the fine operation in the transverse plane thanks to the crossover.



ARCA-SWISS International S.A.R.L.
29, rue de Châtillon, École Valentin
FR-25048 Besançon, France
support@arca-swiss.com
STD: ++33 381 85 40 60

The Functions :

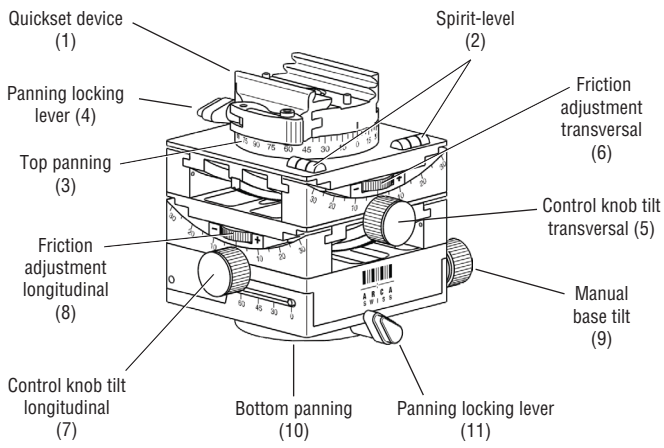

The Cube is mounted through the 3/8" thread in the bottom panning (10) onto the tripod. The turning inner circle of the bottom panning (10) must rest upon a hard, flat surface. The camera is installed onto the ARCA-SWISS quickset device (1). The movement of the camera is effected inside the circular arc, thus a change of the object distance as well as the image selection hardly develops. Through loosening the panning locking lever (11) of the bottom panning (10) the desired image selection is determined and locked. Depending on the kind of image, the camera becomes in one or both axes longitudinal transverse aligned by means of the spirit levels. The manual base tilt (9) is used for camera angles of 30° and above. The range 0-30° should be made by the geared longitudinal control knobs (7). With slope angles under 30° the manual base tilt must be (9) engaged in the zero-position and fixed. After adjustment and leveling of the camera, the top panning (3) can be rotated while the camera remains leveled. The panning locking lever (4) locks the top pan (3). The basic friction of the tilts (transversal/longitudinal) using heavy cameras can be adjusted with the grey friction adjusting wheels (6, 8). If the base friction is correctly adjusted, the camera can be adjusted only by the control knobs (5, 7, 9) or by pushing manually the movement at the Cube head.

Tilt Longitudinal & Transversal ± 30°

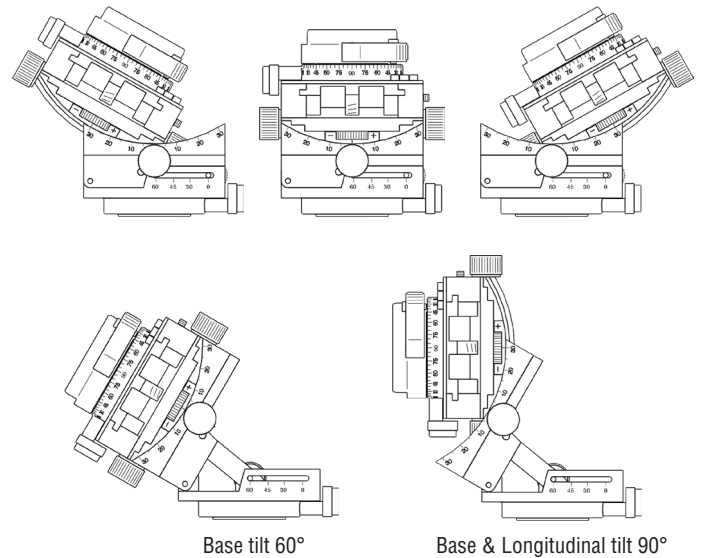

The movement of the camera is effected inside the circular arc, thus a change of the object distance as well as the image selection hardly develops.



ARCA-SWISS quick release device

All tripod heads from ARCA-SWISS are available with a choice of quick release: Classic, flipLock® and monoball®Fix. The Classic and flipLock® systems are equipped with a double dovetail so that you can fit the classic camera plates in the upper dovetail and the monoball®Fix to the bottom. The Fix system is compatible with the monoball®Fix plates. All three of them are compatible with the monorails of the ARCA-SWISS cameras.

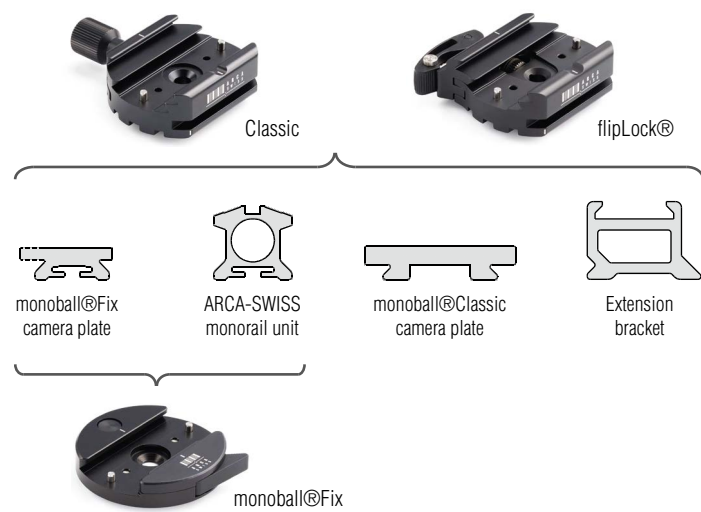

flipLock® instructions :

The ARCA-SWISS flipLock® quick release allows the use of the (most common) ARCA-SWISS "classic" camera plates, thanks to the two levels, all camera plates are also compatible with the new standard monoball®Fix.

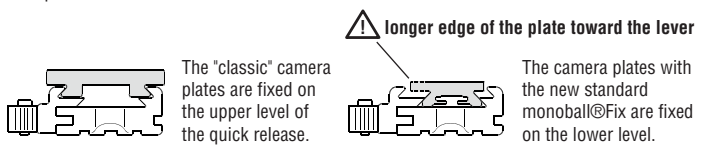

The ARCA-SWISS flipLock® quick release offers an adjustment option that adapt to various camera plates that comply with the "ARCA-SWISS standard". Tolerances may vary from brand to brand.

The ARCA-SWISS quick release flipLock® offers 3 positions:

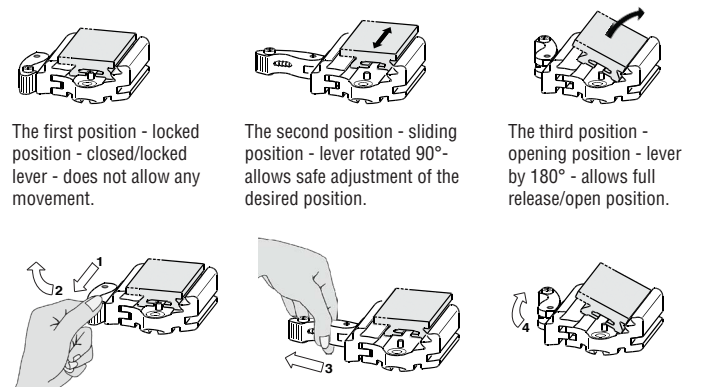

The change from one position to the other is performed as follows:
 1. Pull the release button towards you between your thumb and forefinger.
 2. Then turn the lever 90° to the stop.
 To change from the sliding position to the open position:
 3. Push the serrated pin outward with a press of your thumb.
 4. Then swivel the lever until it is fully open.

monoball®Fix instructions :

1. Open by pulling the clamping lever with your thumb
2. Insert the cameraplate (side opposite the clamping lever)
3. if necessary, center the cameraplate
4. **important:** lock by **clicking** on the clamping lever !

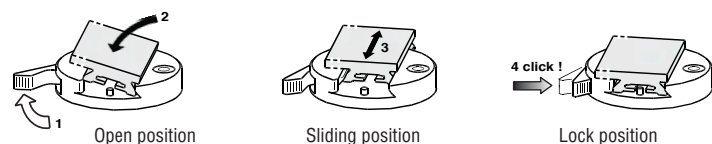

Quickset device Classic instructions :

To open, turn the knob counterclockwise.
 To close, turn the knob clockwise.